

Satellite Block-Upconverter (mini-buc)

Single / Dual / Triple Band
L-Band to C, X, Ku-Band

Modular concept with arbitrary combinations of output frequencies

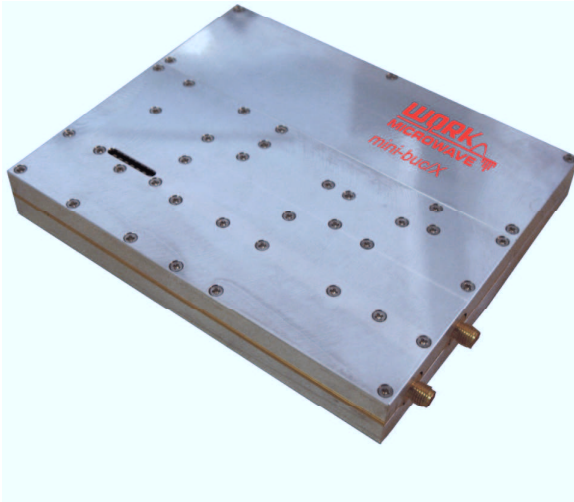

Module
Size: 140x100x17 mm
Weight: 400 g

(Rack Mount- and Outdoor-
Housings are also available)

The mini-buc series of WORK Microwave sets higher standards in modern block converter technology. The usage of integrated circuits provide a most reliable and extremely compact design with very low power consumption and good phase noise. DROs and other critical parts were replaced by MMICs. All mini-buc's are equipped with internal gain control. A built in microcontroller provides an interface to external M&C systems.

Due to the lightweight rugged design, nonsensitive against shock and vibrations, these BUCs can be implemented almost everywhere, e.g. in TWTAs and SSPAs for mobile Land, Sea and Airborne systems. They can be used in satellite news gathering (SNG) terminals as well as mobile satellite communication equipment (Fly-Aways).

19" Rack Mount Housings

WORK Microwave's mini-bucs are also available within a standard 19" rack mount housing for easy rack integration.

Outdoor Housings

The mini-bucs are also available within an outdoor housing, which can be mounted directly behind the antenna.

Key features

- High integrated MMIC technology
- Low phase noise
- Optional OCXO with long term stability 10⁻⁷ / year (with separate module SMBU/HMBU-OCXO)
- Output power +10 dBm (1dB compression point)
- Low spurious emissions
- Low power consumption typ. less than 6 W
- Operating temperature range up to -30 °C to +60 °C
- Reference input through IF interface (standard) or MMCX Connector (option RIN)
- Remote control through RS422/485 (RS 232 option), (with separate module SMBU/HMBU-OCXO RS232 or RS422/485)
- Packet command syntax supports 2-wire or 4-wire bus systems and allows addressed operation
- Summary alarm output (DPDT) (with separate module SMBU/HMBU-OCXO)
- Transmit mute input
- Adjustable gain control (range: 20 dB)
- Can be cascaded to multi converter configurations
- High reliability, Low cost

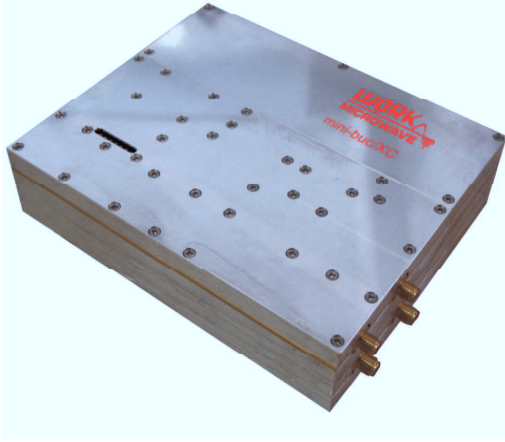

Dual band mini-buc:
 Size: 140x100x34 mm
 Weight: 800 g

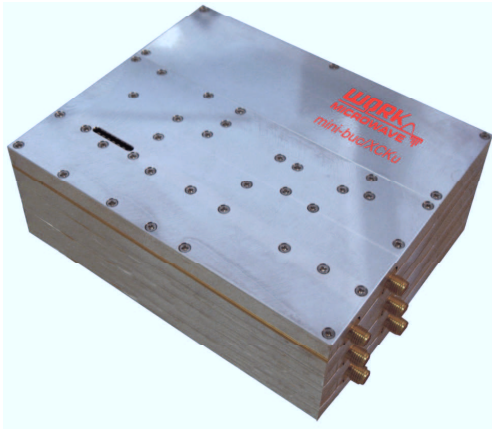

Triple band mini-buc:
 Size: 140x100x51 mm
 Weight: 1200 g

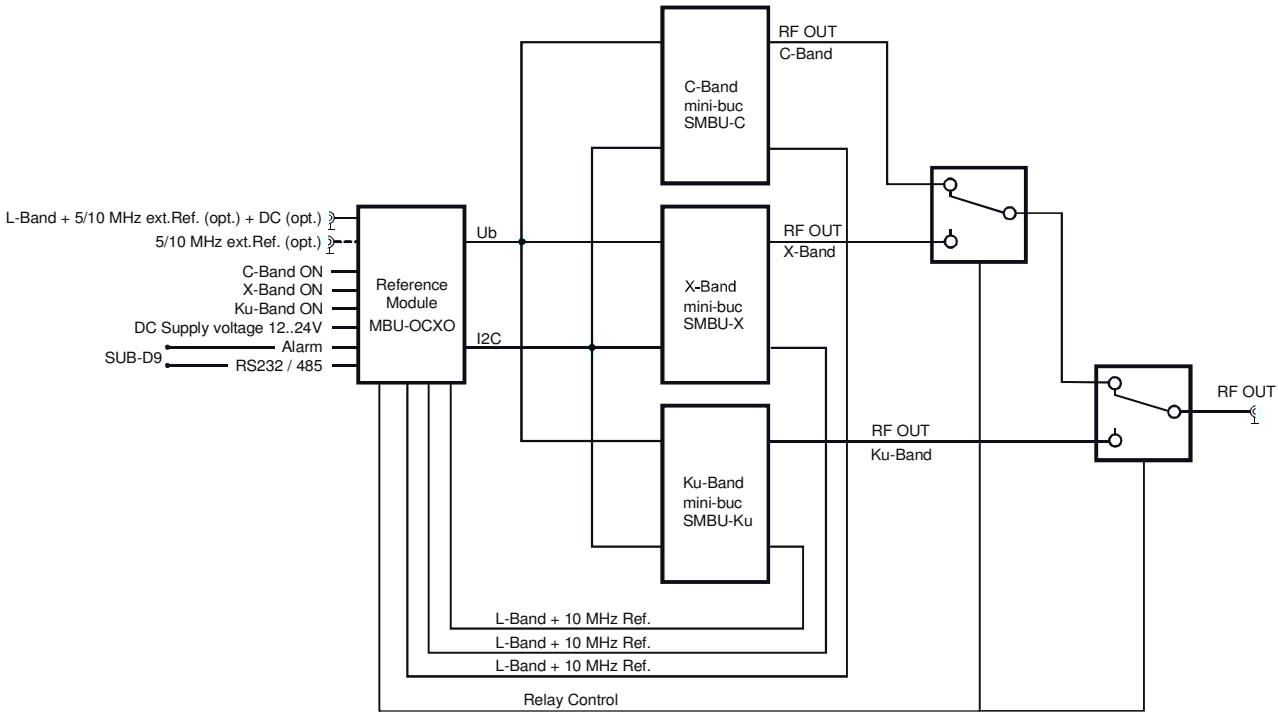

Block diagram of Triple band configuration with reference module

Satellite Block-Upconverter (mini-buc)

Modules

Single / Dual / Triple Band L-Band to C, X, Ku-Band
S-Type (standard version), H-Type (extended temperature range)

Single Band Type:	SMBU-C, SMBU-X, SMBU-Ku or HMBU-C, HMBU-X, HMBU-Ku		
Dual Band Type:	SMBU-CX, SMBU-CKu, SMBU-XKu or HMBU-CX, HMBU-CKu, HMBU-XKu ¹⁾		
Triple Band Type:	SMBU-CXKu or HMBU-CXKu ¹⁾		
RF-Output Frequency:	C-Band 5.850...6.450 GHz	X-Band 7.9...8.4 GHz	Ku-Band Ku1: 13.75...14.50 GHz Ku3: 12.75...13.50 GHz
LO Frequency:	4.9 GHz	6.95 GHz	12.8 GHz (Ku1) 11.8 GHz (Ku3)
Phase Noise:	10 Hz 100 Hz 1 kHz 10 kHz 100 kHz 1 MHz	... -58 -70 -80 -89 -95 -115	-58 -70 -80 -89 -95 -115
			-54 -66 -76 -85 -93 -115
		max values in dBc/Hz	
IF-Input Frequency	950 ...1550 MHz	950 ...1450 MHz	950 ...1700 MHz
Conversion Scheme:	Block up conversion, no frequency inversion		
IF-Input Characteristics:	Impedance: Return Loss: Connector:	50 Ω > 18 dB SMA (female)	
RF-Output Characteristics:	Impedance: Return Loss: 1 dB Compression Point: Output Muting: Connectors:	50 Ω > 18 dB > 10 dBm -75 dBc min (by command or sense input or by alarm condition) SMA (female)	
Transfer Characteristics:	Max Conversion Gain: Attenuation range: Gain Variation over Temp.: Gain Flatness over Freq.: Gain Flatness over 40 MHz: Image Rejection: Noise Figure:	35 dB ± 2 dB 20 dB ± 2 dB (Option LG) 0...20 dB, 0.1 dB steps ± 1 dB max ± 1.5 dB max. over band ± 0.5 dB > 80 dB < 15 dB	
Group Delay:	Variation:	< 1 ns peak-peak / 80 MHz max.	
Spurious Outputs:	Signal related: Signal independent:	< -65 dBc < -85 dBm	
Intermodulation (3rd Order):	-53 dBc max @ two equal tone carrier , 5 MHz distance: P _{in} 2 x -18 dBm, P _{out} : 2 x -8 dBm (Att=10dB)		
Reference Input:	Frequency: Level: Input: Phase Noise: 10 Hz 100 Hz 1 kHz 10 kHz 100 kHz 1 MHz	10 MHz sine wave 5 dBm ± 5 dBm through IF input (standard) through MMCX connector (Option RIN) -116 dBc/Hz max -128 dBc/Hz max. -138 dBc/Hz max. -148 dBc/Hz max. -158 dBc/Hz max. -160 dBc/Hz max	
Monitoring and Control Interface:	Protocol: Connection:	Multipoint RS422/RS485 (Option RS232)	
Out of lock indicator:	Open Collector (shorted to ground when unlocked) Automatic muting when unlocked		
Temperature Range:	SMBU: 0°C to +50°C HMBU: -30°C to +60°C -46°C to +73°C	operational operational storage	
Relative Humidity:	< 95 % non condensing, MIL-STD-202F		
Power Input:	12...24 V DC via IF input or external connector		
Power Consumption:	6 W (single band)		
Dimension and Weight:	Single-Band: L x W x H: 140 x 100 x 17 mm, < 400 g Dual-Band: L x W x H: 140 x 100 x 34 mm, < 800 g Triple-Band: L x W x H: 140 x 100 x 51 mm, < 1200 g		
Low Pressure/Altitude:	50,000 feet max., MIL-STD-810E		
Shock/Vibration:	MIL-STD-202F		

Specifications are subject to change

1) SMBU-OCXO or HMBU-OCXO and RF relays are included

Satellite Block-Upconverter (mini-buc)

Modules

Single / Dual / Triple Band L-Band to C, X, Ku-Band

S-Type (standard version), H-Type (extended temperature range)

Order Information:

**SMBU-[RF Band(s)] or
HMBU [RF Band(s)]**

Possible Options are:

LG (Low Gain)

RIN (Ref input via MMCX Connector instead of IF input)

RS232 (Remote control through RS232 instead of RS422/485)

IDU (mounted in 19" rack housing, no power supply, no local control)

ODU (mounted in outdoor housing, no power supply, no local control)

OD (mounted in outdoor housing, with power supply, no local control)

Examples:

SMBU-CXKu1 (Triple band minibuc, SMBU-OCXO and rf-relay are included)

HMBU-Ku (Single band Ku-Band minibuc, extended temperature)

SMBU-Ku-LG (Single band Ku-Band minibuc, low gain)

Block-Converter Reference Module



10 MHz Reference- and Main-Module for mini-buc S-Type (standard version), H-Type (extended temperature range)

Type:	SMBU-OCXO or HMBU-OCXO	
OCXO Phase Noise (typical)	10 Hz 100 Hz 1 kHz 10 kHz 100 kHz 1 MHz	- 115 dBc/Hz max. - 136 dBc/Hz max. - 147 dBc/Hz max. - 152 dBc/Hz max. - 159 dBc/Hz max. - 161 dBc/Hz max.
Reference Output:	Frequency: Level: Connector:	10 MHz 3 dBm ±1 dBm SMA
External Reference Input:	Frequency: Level: Connector: Mode:	5 or 10 MHz ±2 ppm 5 dBm ± 5 dBm SMA auto
Internal frequency Stability:	± 1 x 10 ⁻⁷ 0°C to 50°C ± 2 x 10 ⁻⁸ 0°C to 50°C (after 30 min warm up) ± 1.5 x 10 ⁻⁹ per day (fixed temperature after 24 h warm up)	
IF-Input Characteristics:	Frequency: Impedance: Return Loss: Connector:	950 MHz...1700 MHz 50 Ω > 15 dB SMA (female)
IF-Output Characteristics:	Frequency: Impedance: Return Loss: Connector:	950 MHz...1700 MHz 50 Ω > 15 dB SMA (female)
IF Transfer Characteristics:	Max Loss:	2 dB includes switch for IF-signal
Relay Driver:	Support of two RF relays	
Monitoring and Control Interface:	Protocol: Connection:	Multipoint RS422/RS485 or RS232
Alarm-Output:	Two potential free contacts (DPDT)	
Temperature Range:	SMBU-OCXO: HMBU-OCXO:	0°C to +50°C operational -30°C to +60°C operational -46°C to +73°C storage
Relative Humidity:	< 95 % non condensing, MIL-STD-202F	
Power Input:	12...24 V DC	
Power Consumption:	approx 5 Watt	
Dimension and Weight:	Single-Band: L x W x H: 140 x 100 x 20 mm, approx 350 g	
Low Pressure/Altitude:	50,000 feet max., MIL-STD-810E	
Shock/Vibration:	MIL-STD-202F	

Specifications are subject to change

Order Information: SMBU-OCXO or HMBU-OCXO